

P2P Food Lab

Get started

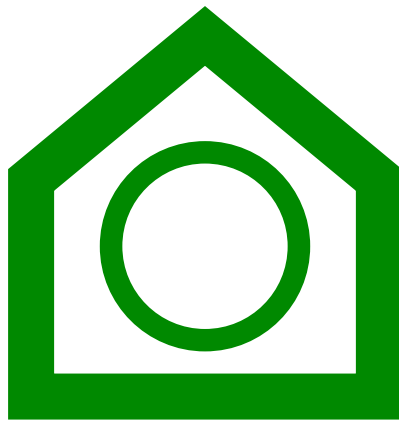

Make 3D vegetables !

How to make the P2P Food Lab
greenhouse and sensorbox, and
how to start growing food.

Early draft, Sept 2013

Greenhouse

- 1. structure**
- 2. cover**
- 3. finishing**

Sensorbox

- 1. hardware**
- 2. software**

Web site

- 1. sensor data**
- 2. know-how & sharing**

Make food !

re-Make the world !

Greenhouse

1. structure



The dimensions of the greenhouse elements

Inside width of the greenhouse, in centimeters:

Inside depth of the greenhouse, in centimeters:

Inside height of the greenhouse, in centimeters:

Length of the battens from which the greenhouse will be made:

Section of the battens (square):

Thickness of the board used to make the box:

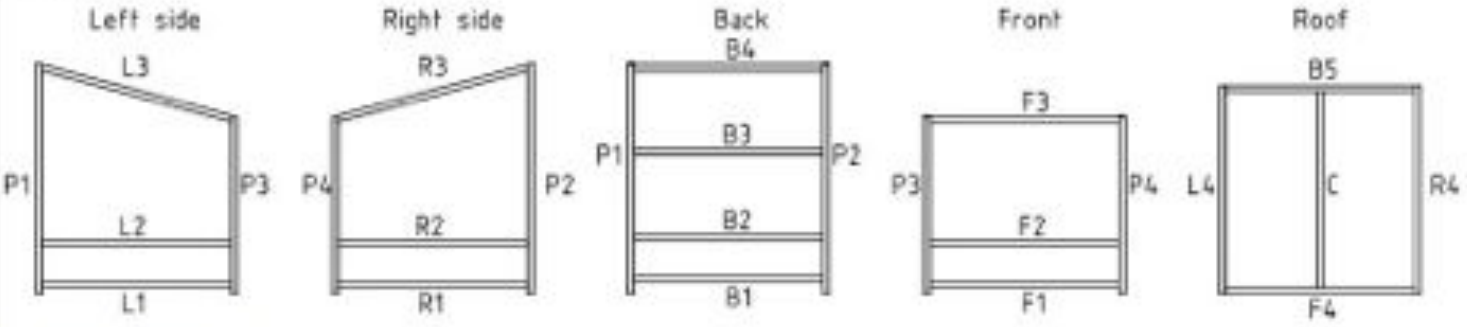

Summary of the dimensions:

Inside dimensions (WxDxH) 120.0 x 120.0 x 144.3
 Outside dimensions (WxDxH) 128.0 x 128.0 x 146.4
 Number of battens (250 cm) 15

The complete list of elements, with their name and length, is given below:

Name	Length (cm)	Length including edges	Angles	Batten
P1	144.3		90, 75	Batten 1
P2	144.3		90, 75	Batten 2
P3	110.5		90, 75	Batten 3
P4	110.5		90, 75	Batten 4
L1	124.0		90, 90	Batten 14
L2	124.0		90, 90	Batten 15
L3	128.4	128.9	75, 75	Batten 7
L4	132.5		90, 90	Batten 3
R1	132.5		90, 90	Batten 4
R2	132.5		90, 90	Batten 5















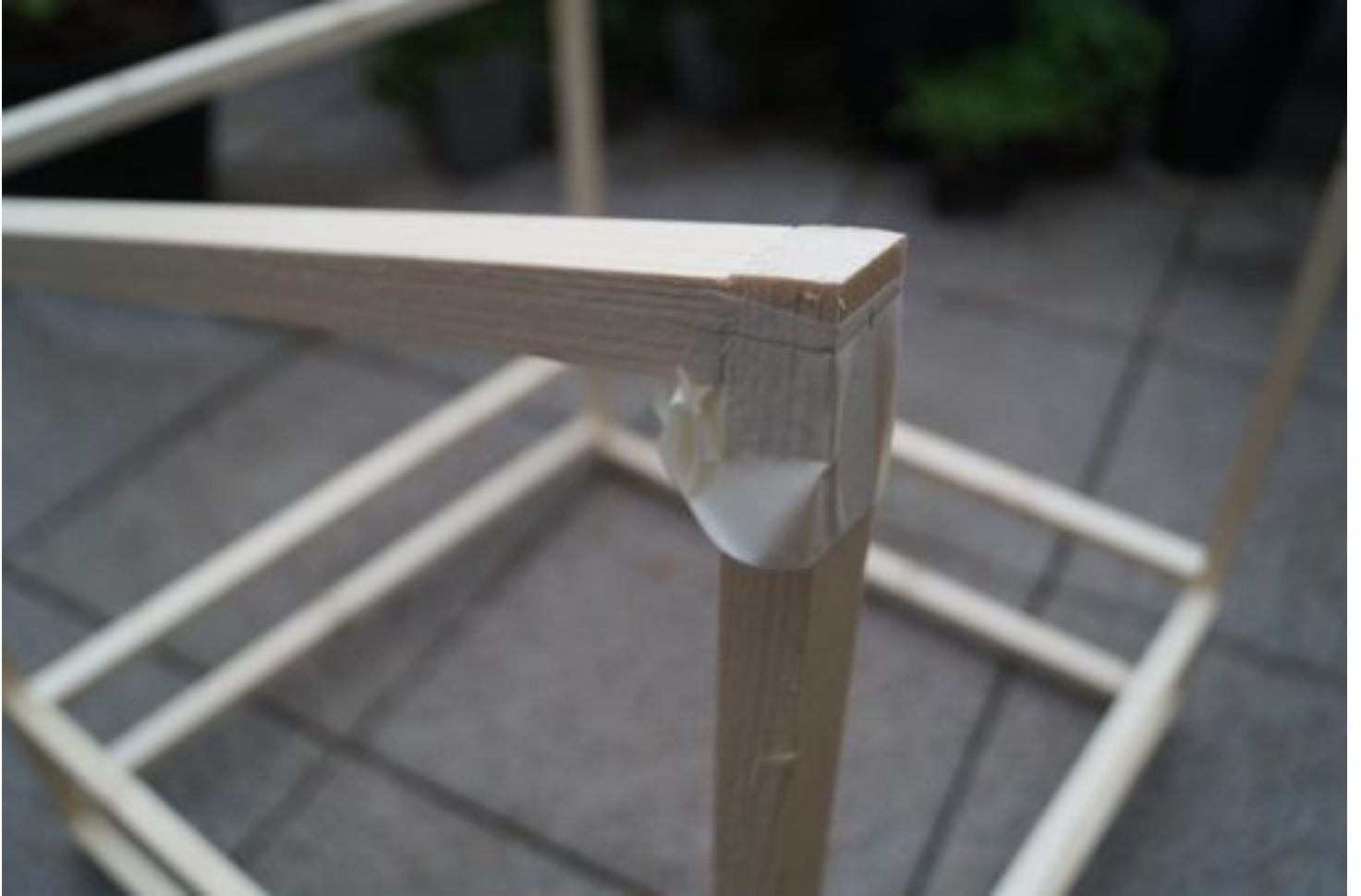







Greenhouse

2. cover





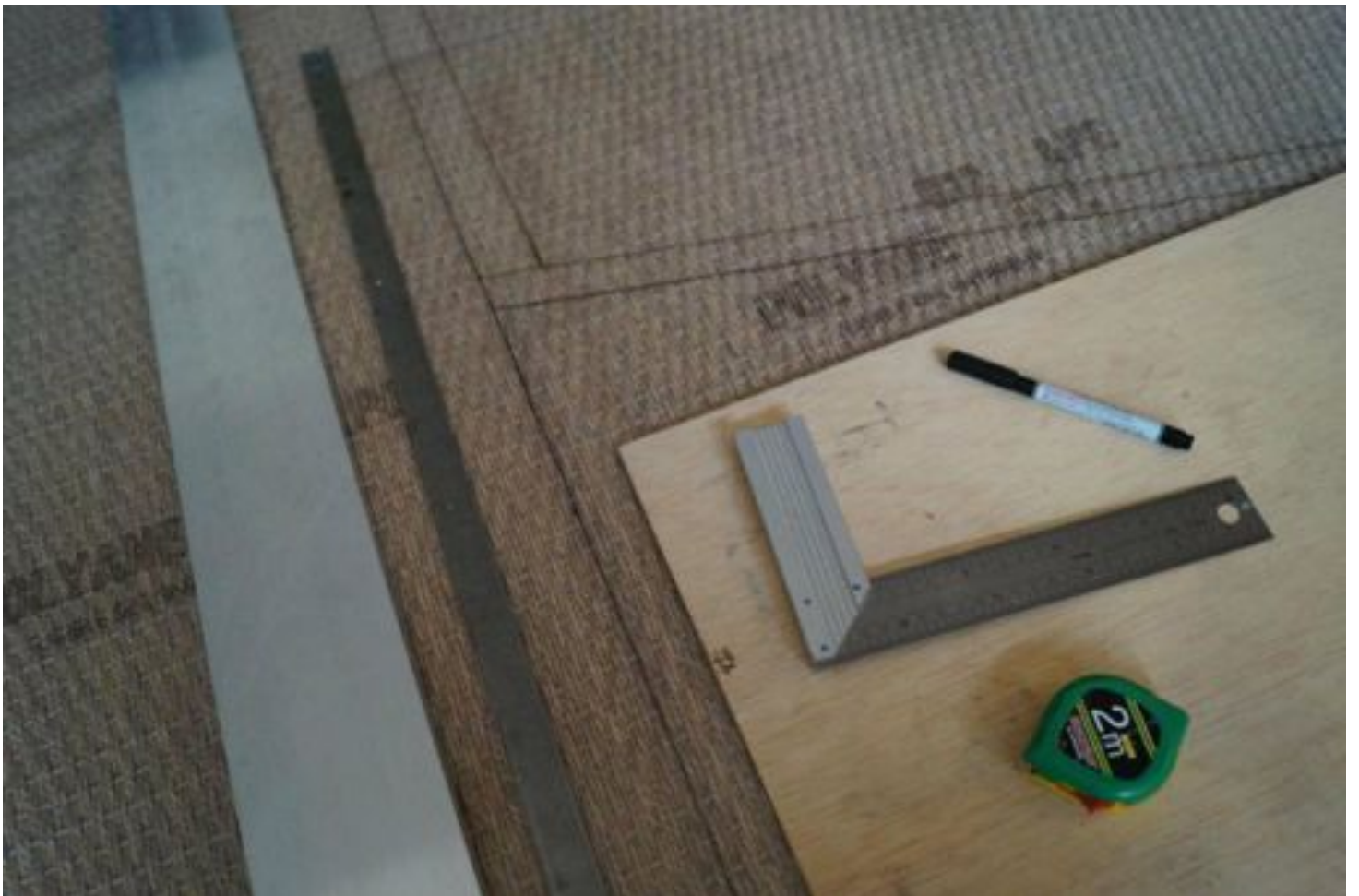









Greenhouse

3. finishing





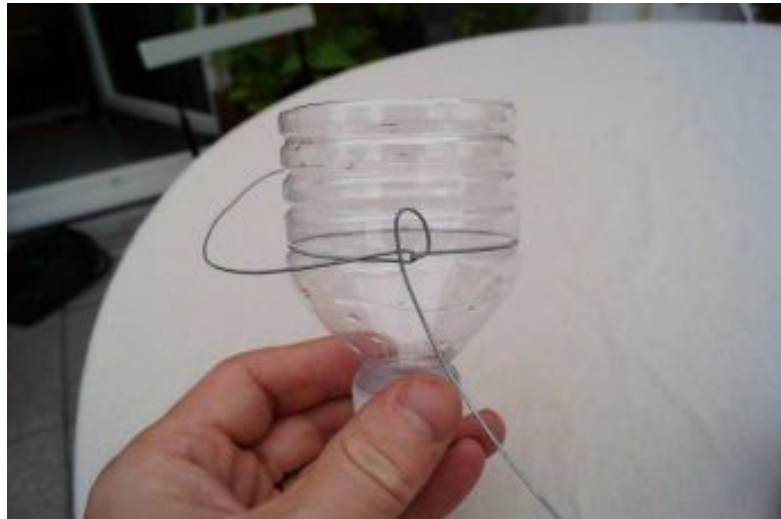





Cost

TODO

- * Improve insulation
to keep the greenhouse warm in winter**
- * Improve heat storage
to avoid overheating in summer
(sun screen, heat storage)
to retain warmth of winter sun**
- * Improve ventilation**
- * Add frame for vertical crops.**

Sensorbox

1. hardware

Greenhouse

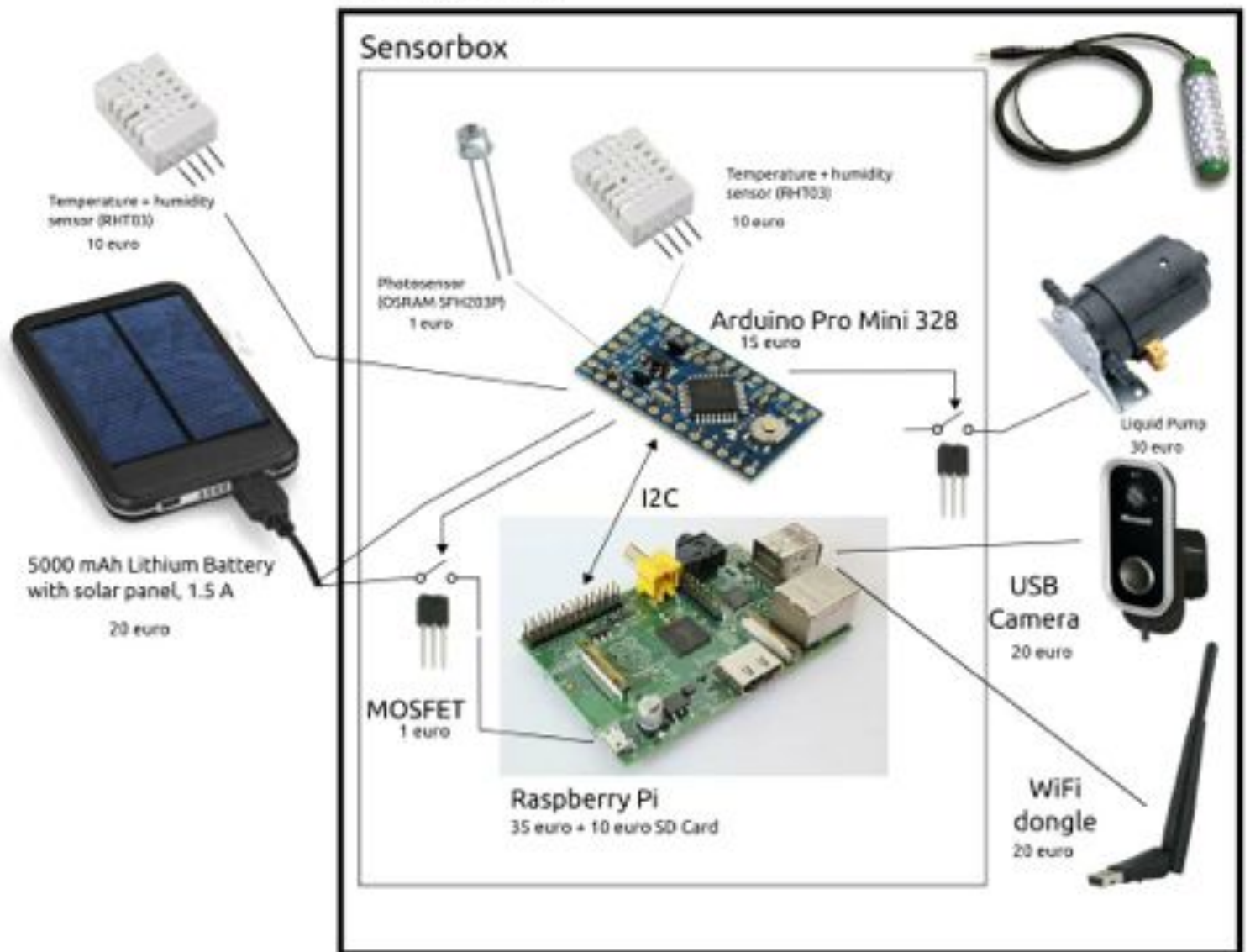

Component list

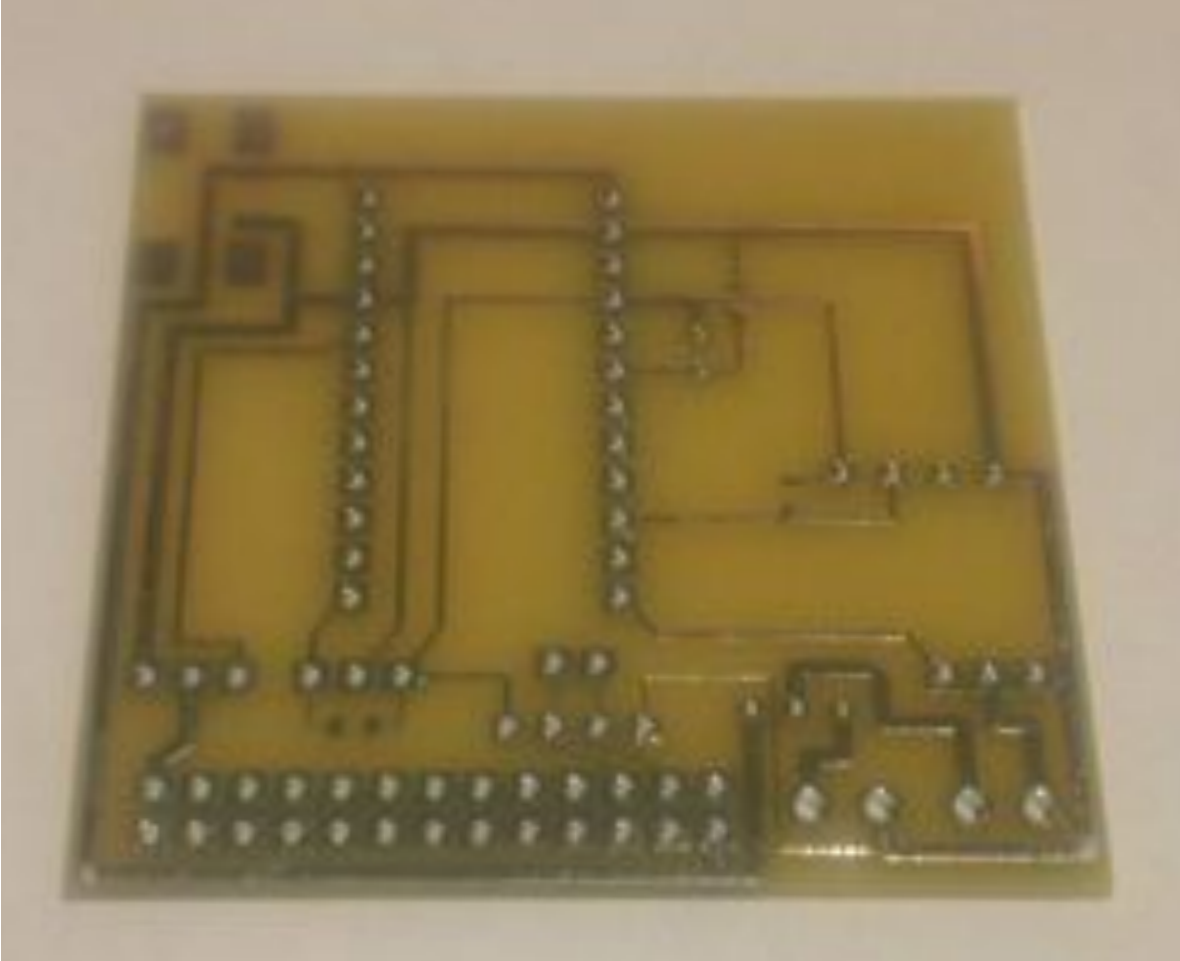
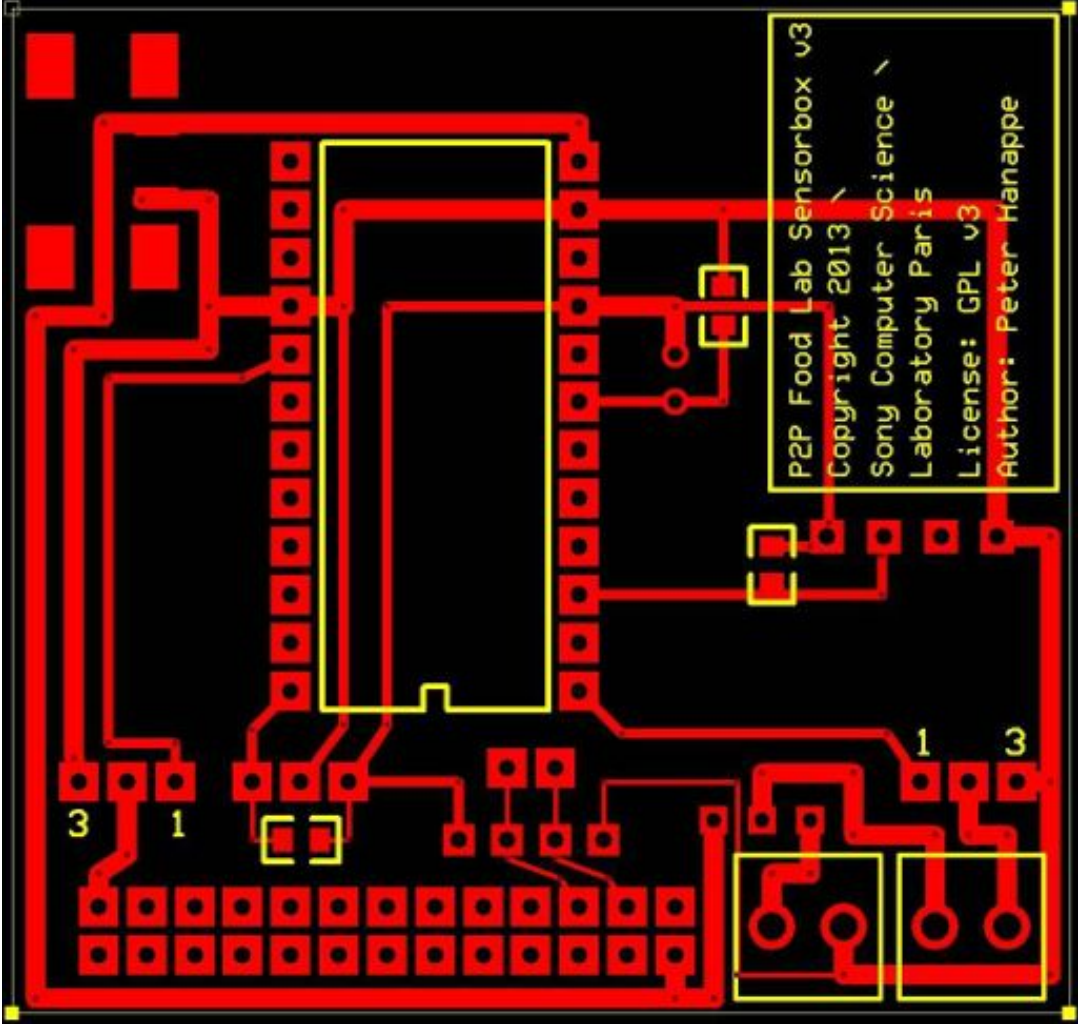

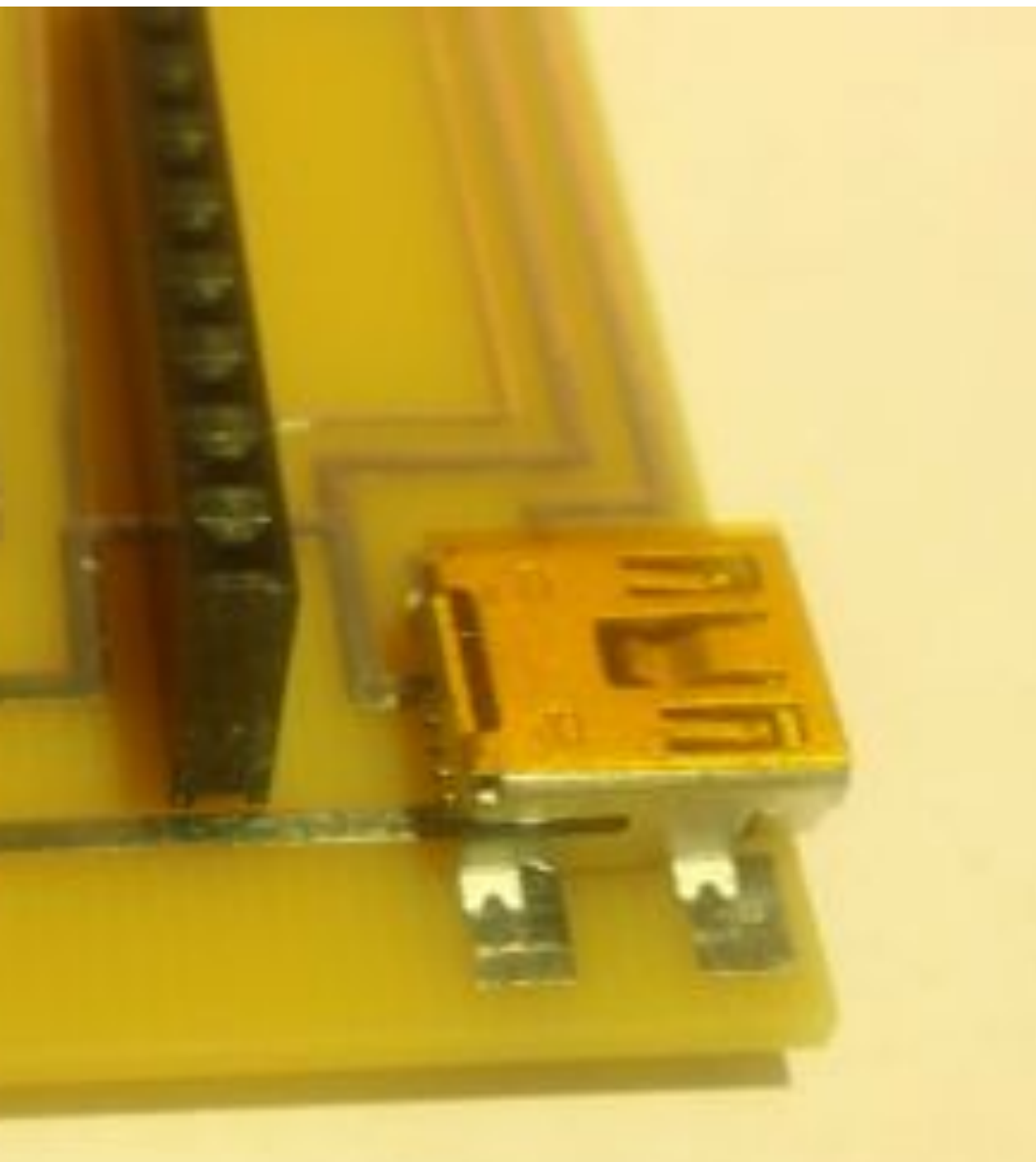

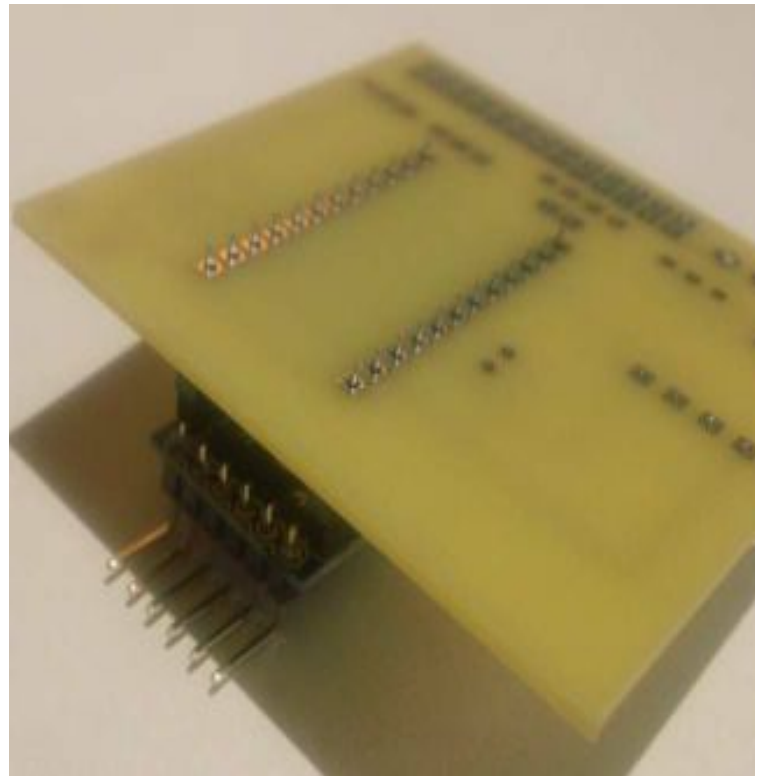
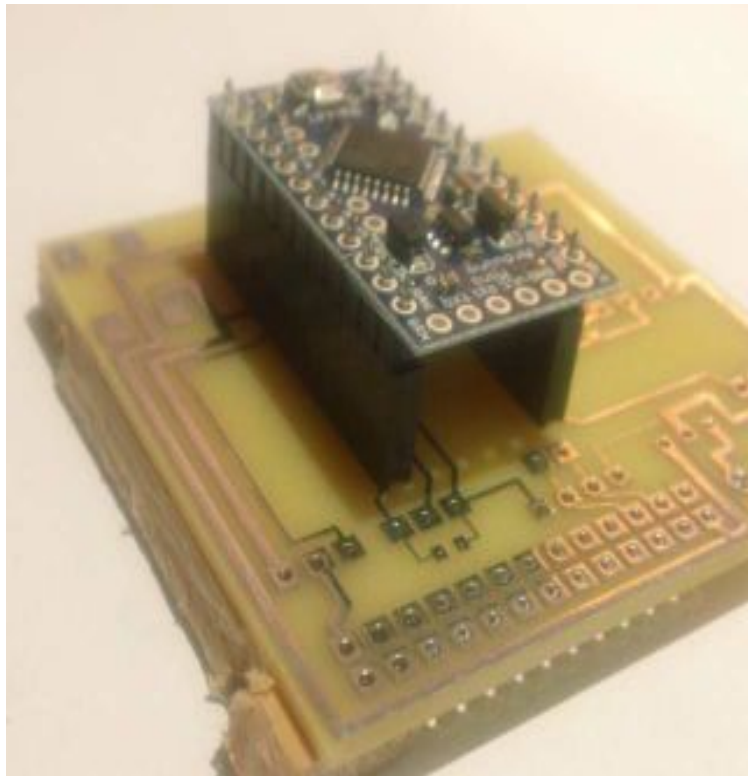
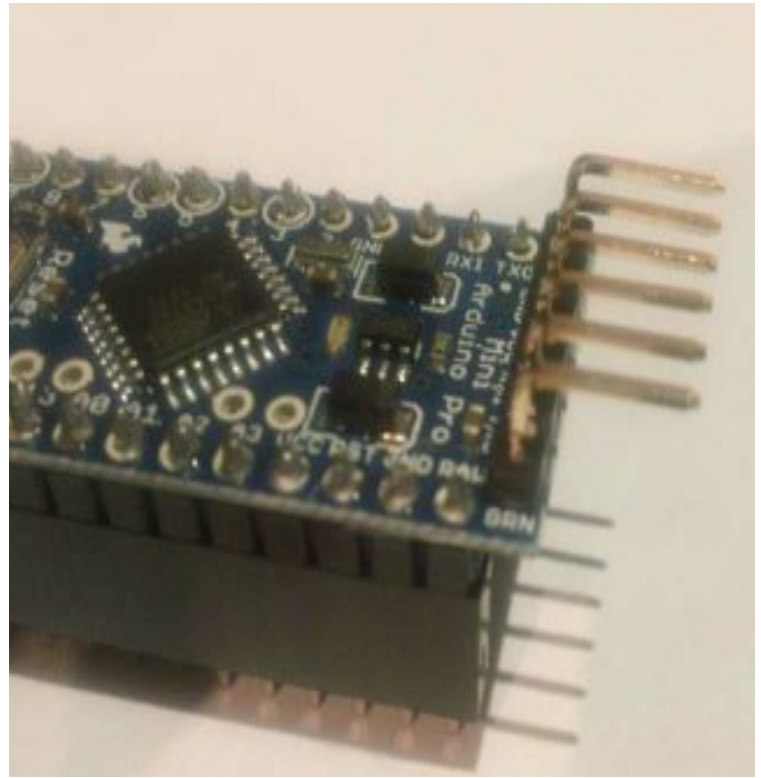
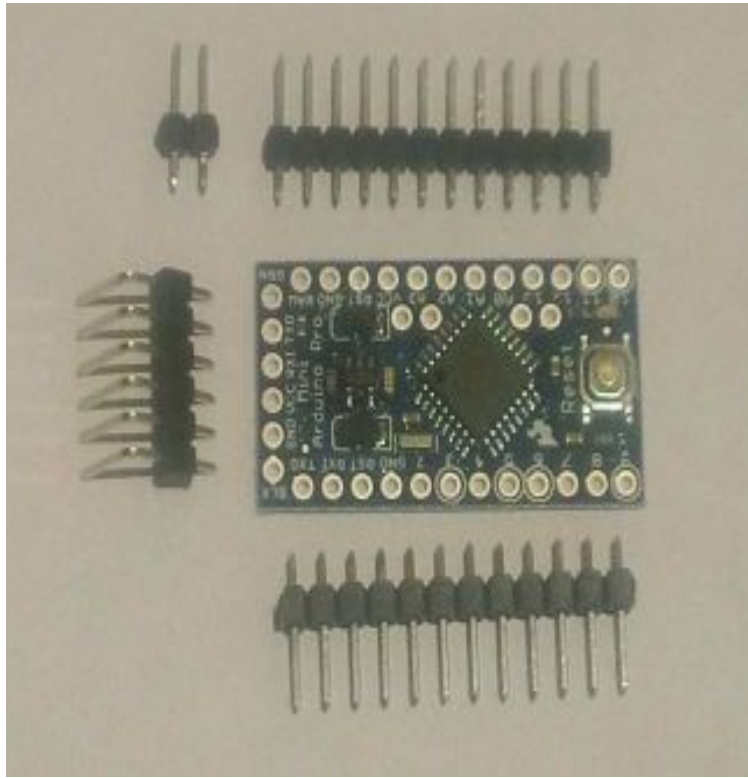

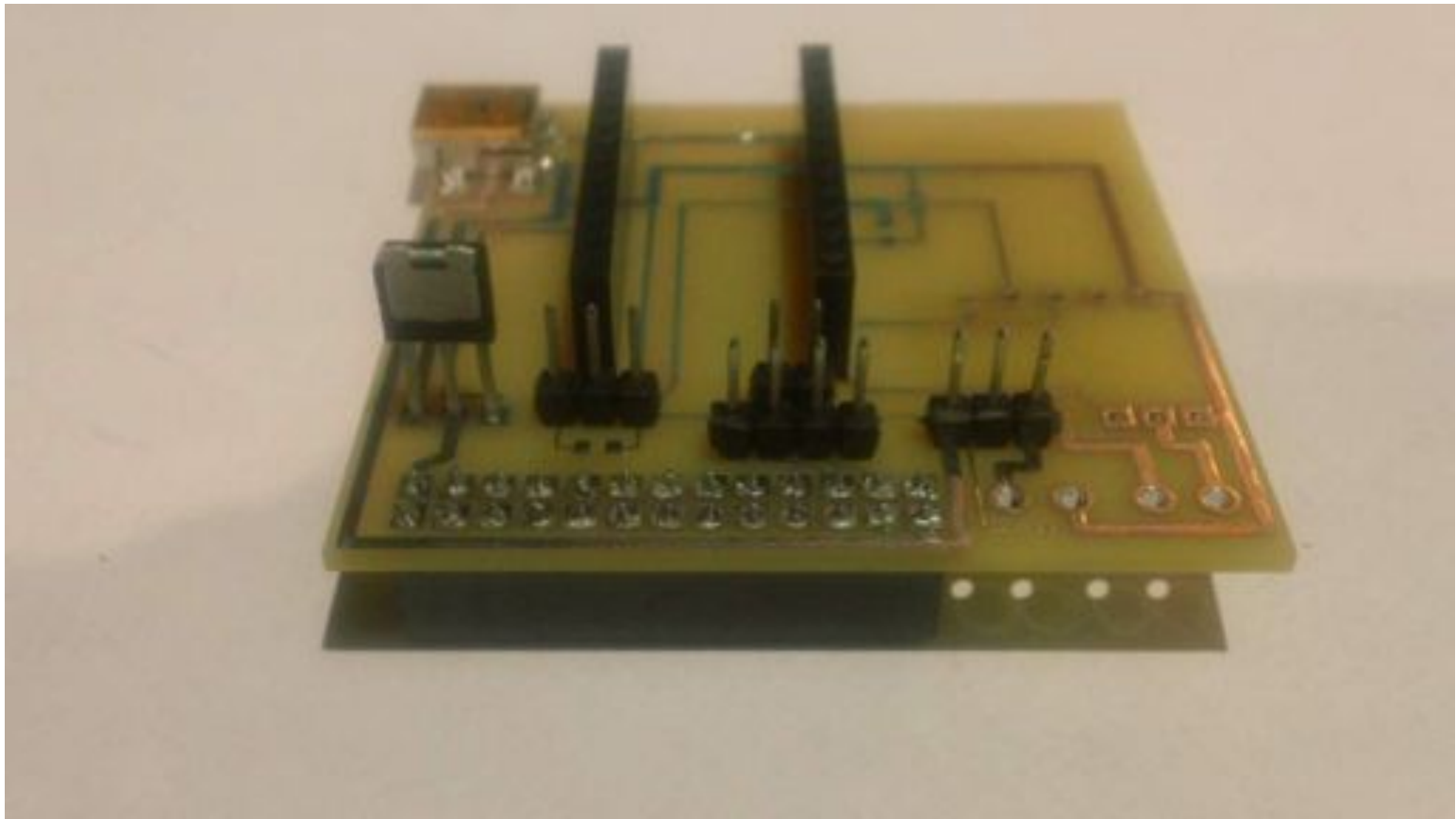

I2C

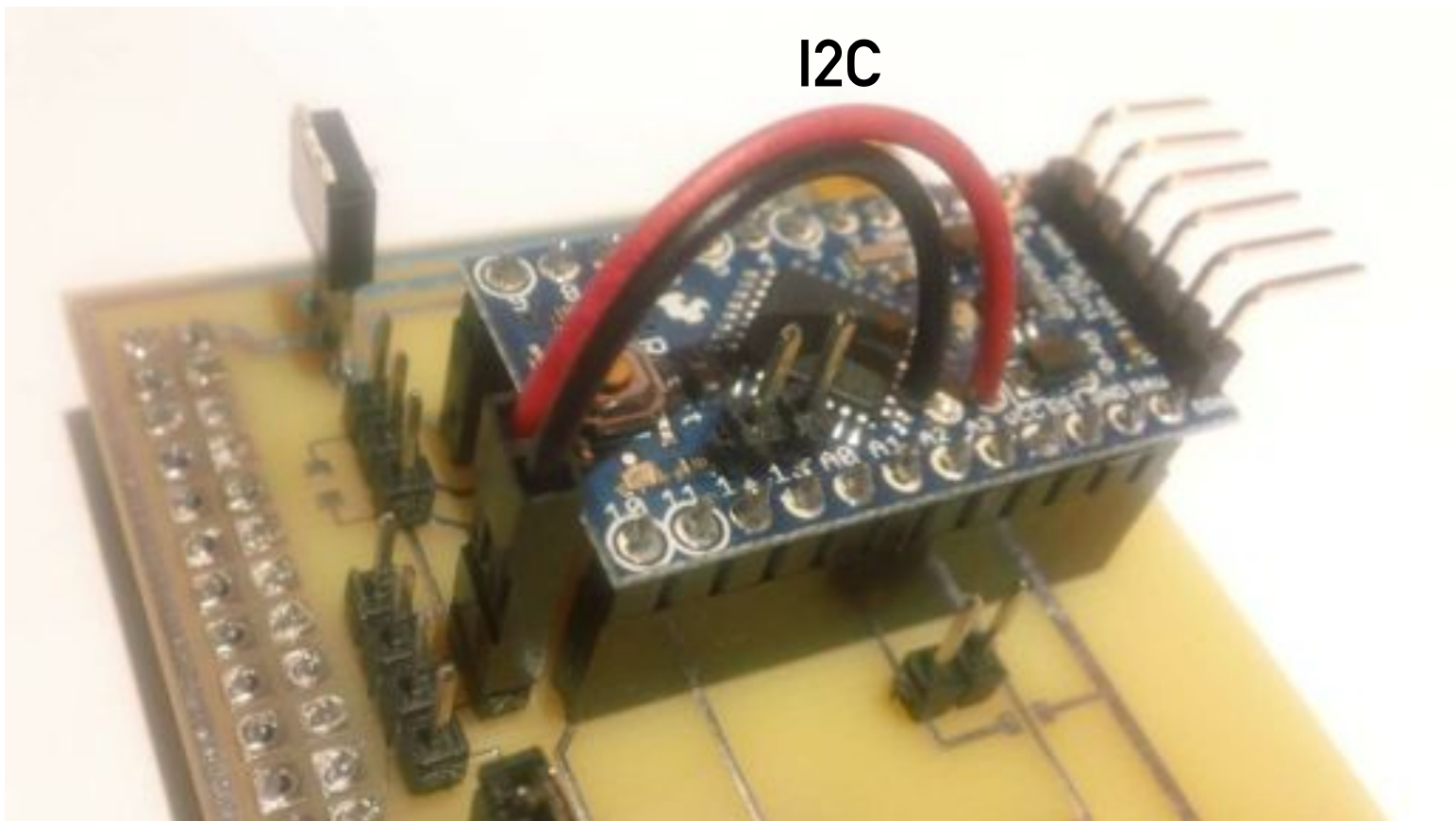

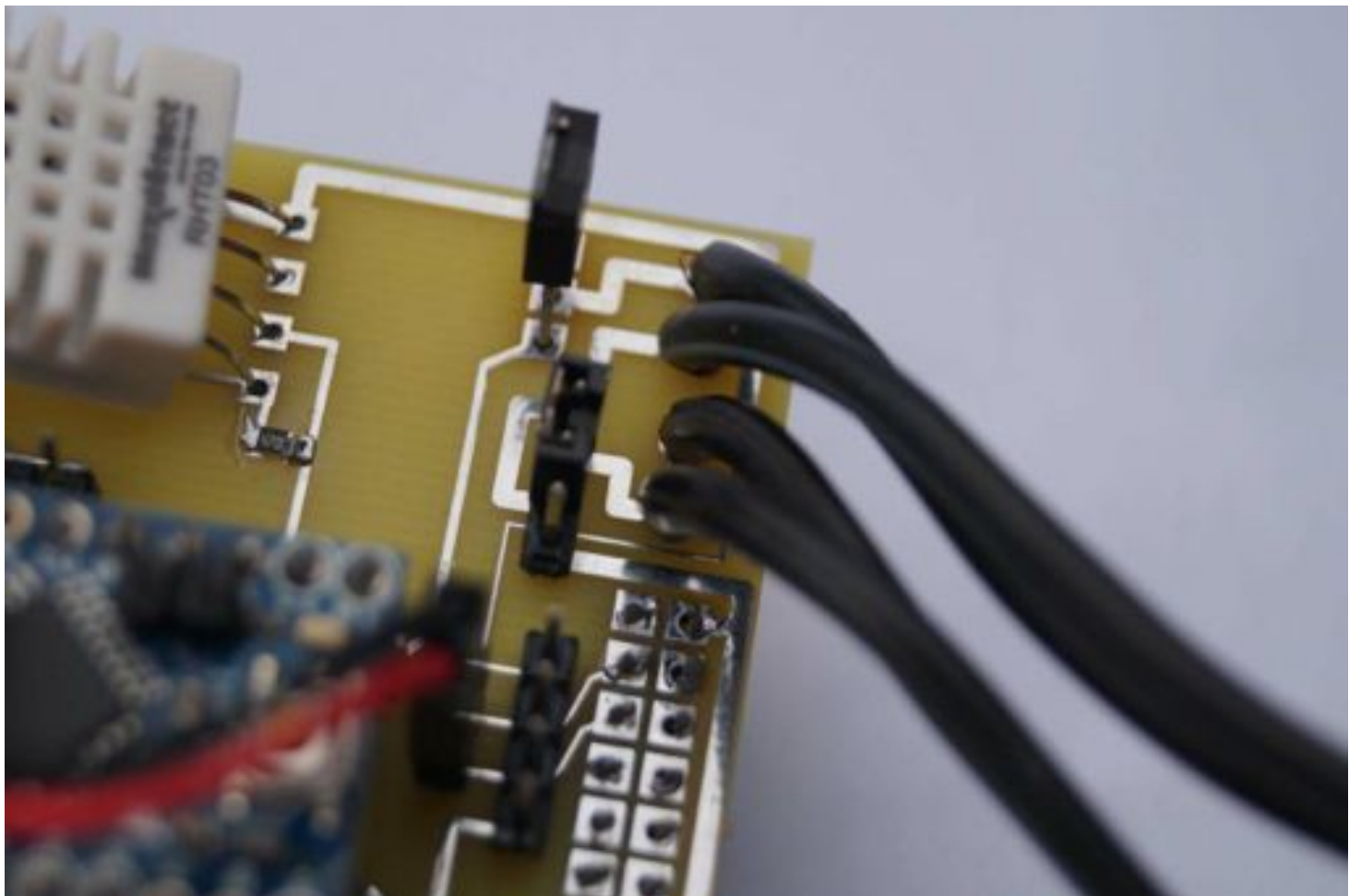
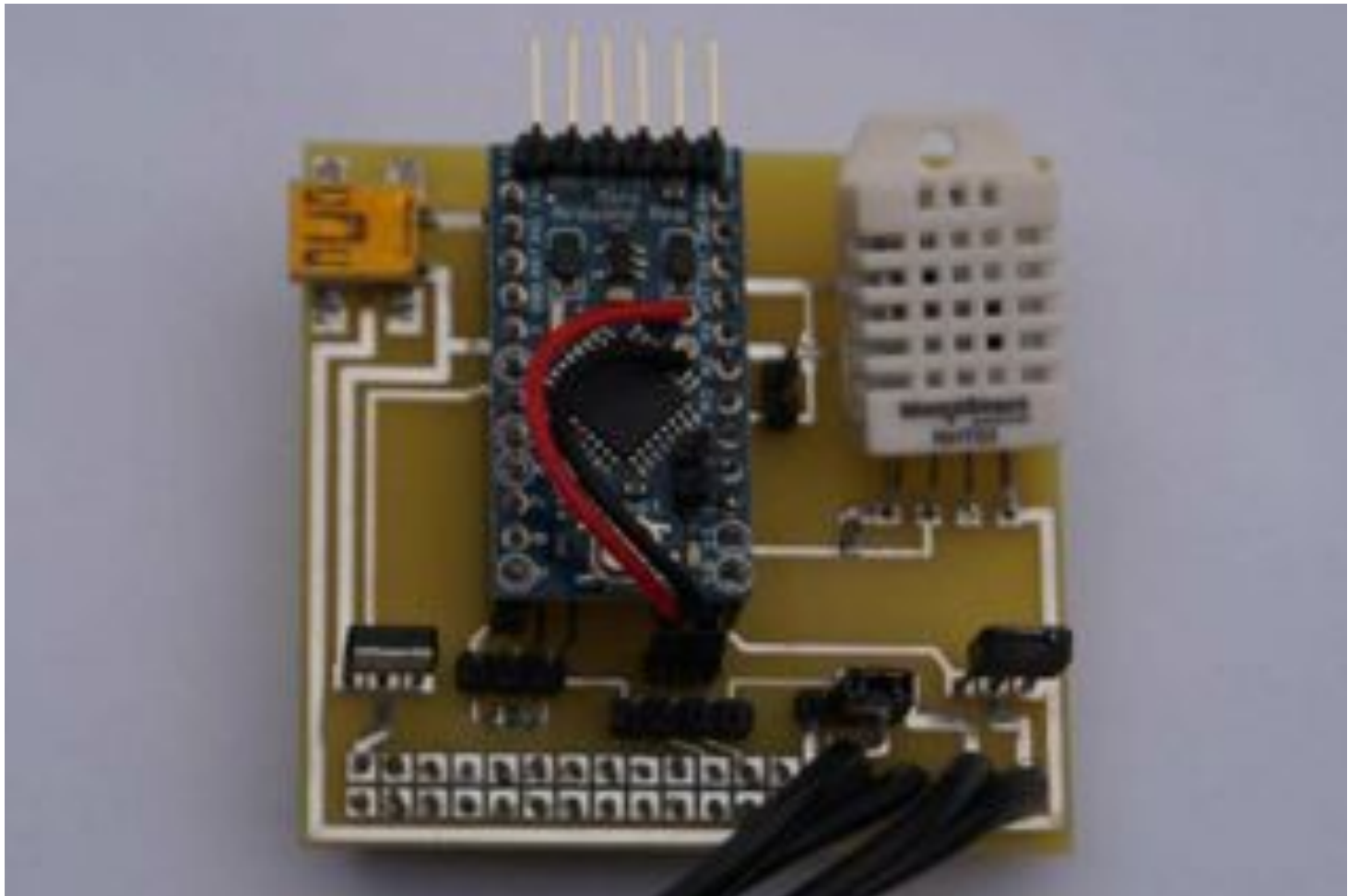











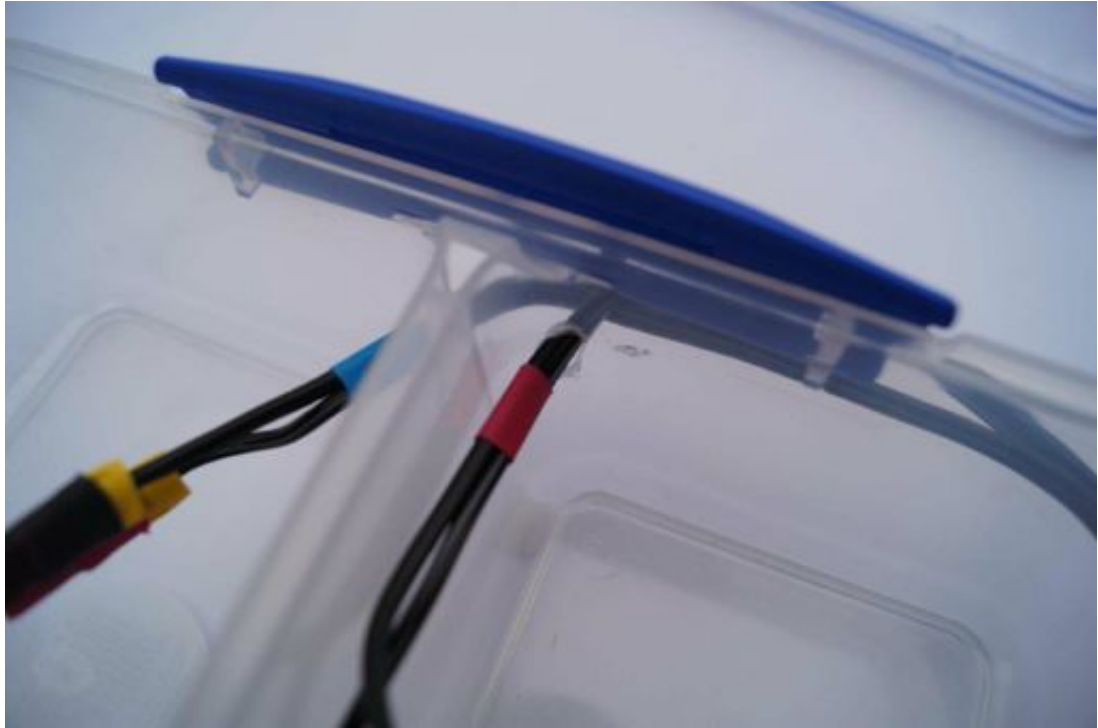
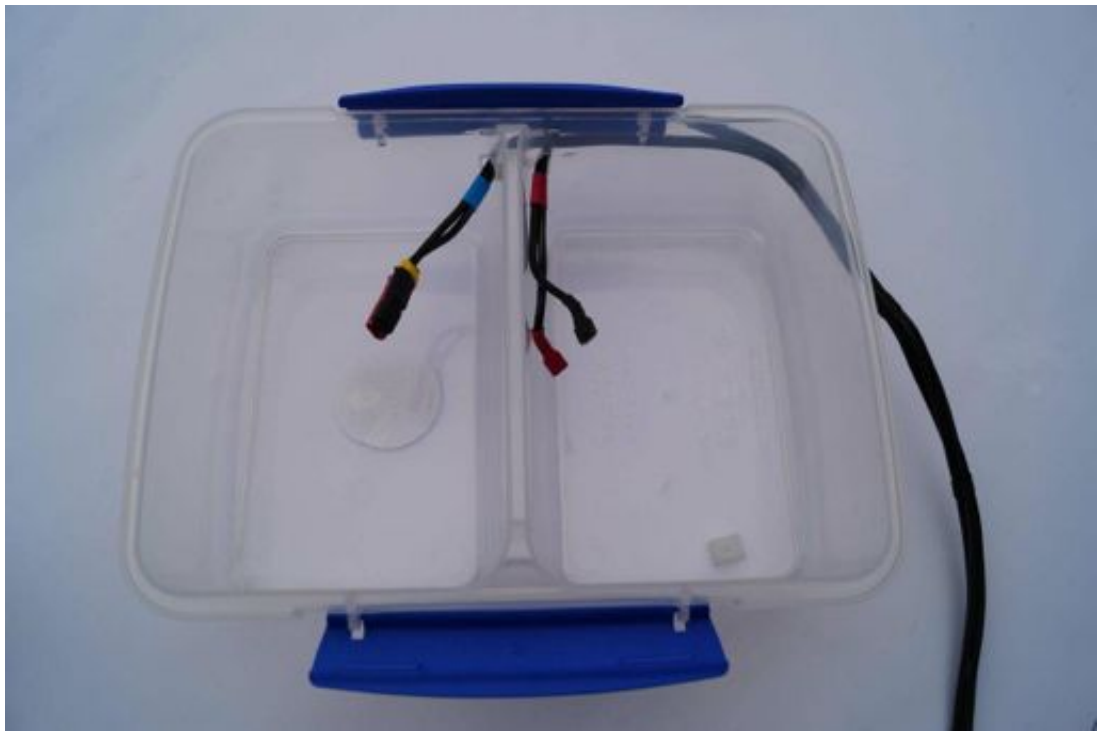







TODO

- * more testing of solar batteries
- * use one or two batteries?
- * detect water level / improve pump
- * cheap and reliable soil humidity sensor
- * renewable power source
- * network of sensors for large gardens?

Sensorbox

2. software



Ethernet cross-cable
or
Ethernet switch



DHCP server
& HTTP server
IP 192.168.3.14

Configuring the sensorbox

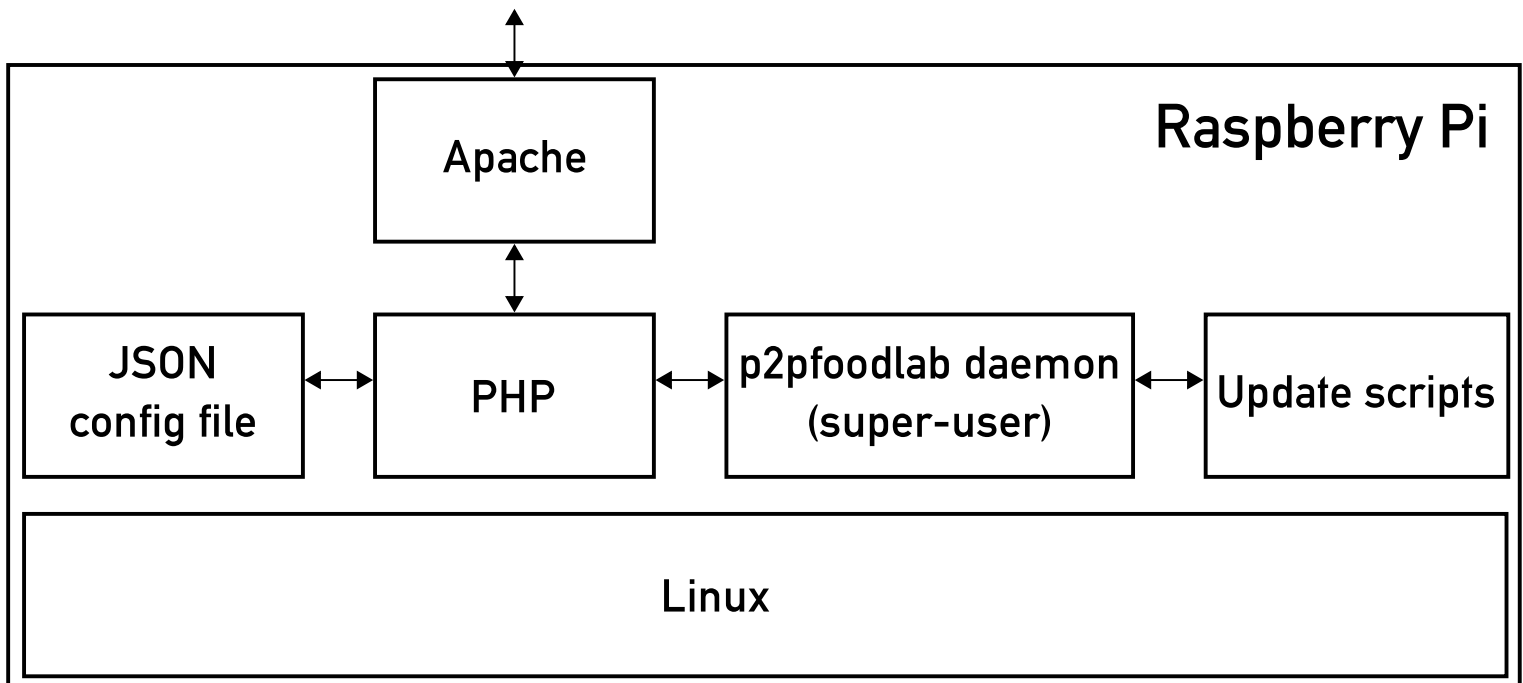
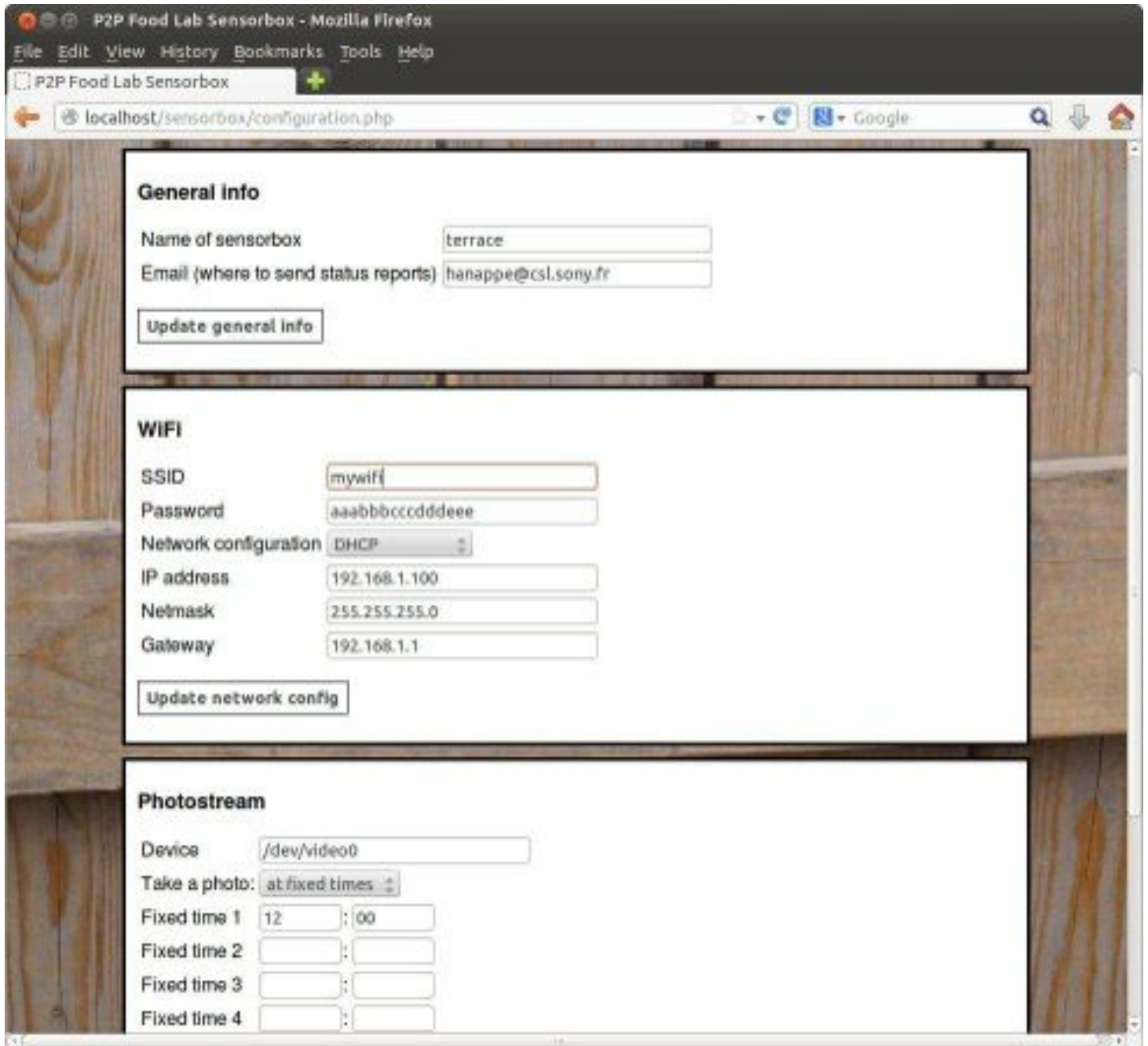

Communicating with the arduino:

We developed a small utility to talk to the arduino:

```
$ arduino --help
```

```
arduino [command] [options]
```

Commands:

- | | |
|------------------------|--------------------------------|
| - enable-sensors flags | Enable sensors |
| - store-data | Download and store sensor data |
| - poweroff minutes | Shutdown the Raspberry Pi |
| - millis | Get the current clock |
| - pump seconds | Turn on/off the pump |

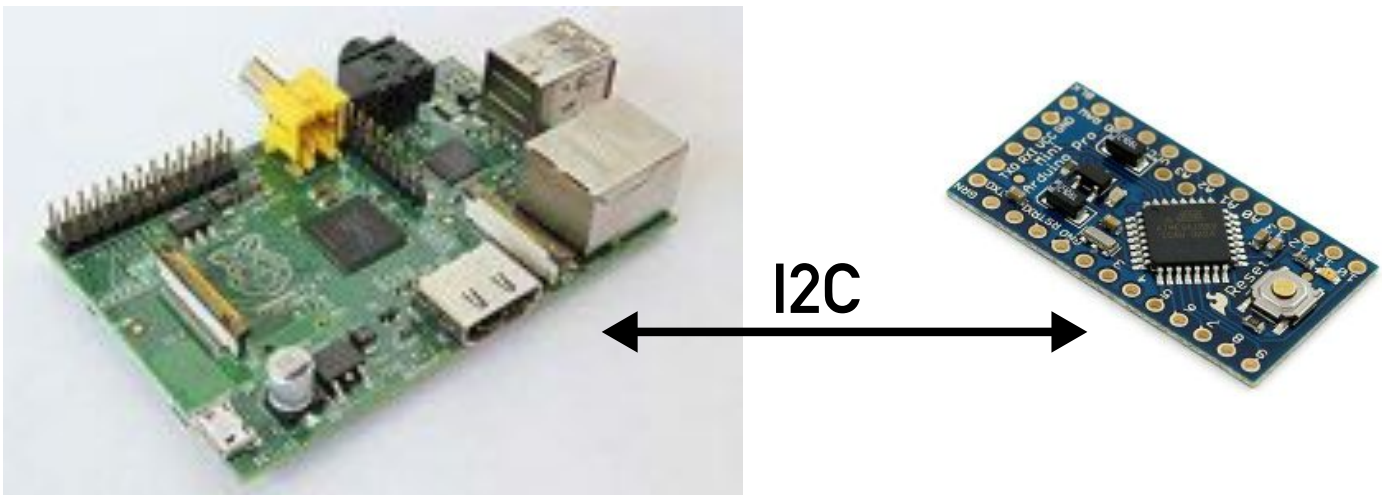

Linux: C-interface <linux/i2c-dev.h>

Arduino: Wire library

Keeping time

The Raspberry Pi does not have a "real-time clock". This means that it does not know the current time when it starts.

It updates its time by asking another machine on the network, using the Network Time Protocol (NTP). For remote usage, over GSM networks for example, NTP is not reliable. The software package "fake-hwclock" assures that clock is set to the date and time that the RPi shut down.

We improved this strategy by adjusting the RPi clock using arduino's clock.

Web site

1. sensor data

OpenSensorData.net

P2P Food Lab web site

- view images

- view data

Data analyses

- amount of sunlight**
- temperature efficiency of greenhouse**
- growth patterns of plants**

Web site

**2. know-how
& sharing**

Make food !

Square-foot gardening

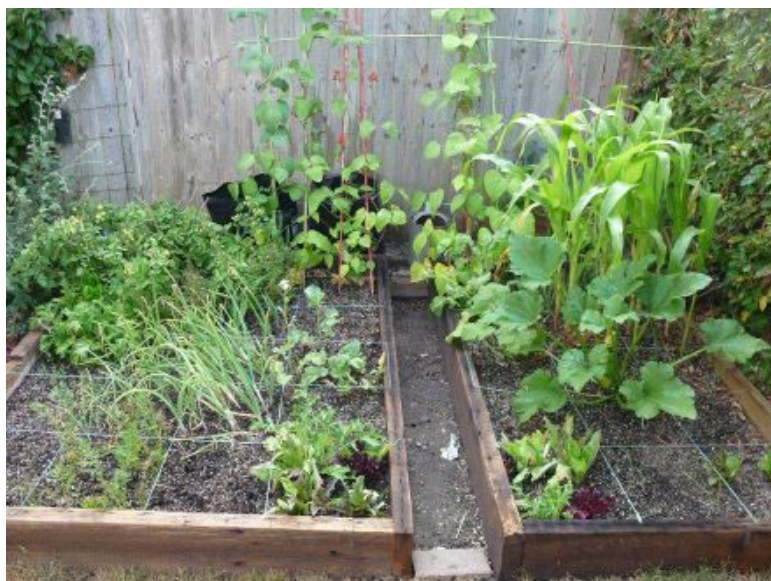

Images by
- Dale Calder
- Océane Peisey / Michka Mélo
- Peter Hanappe
- Stephen Ticehurst (mrmole)
- Erica Smith



TOMATO (2x1)

CUCUMBER (2x1)

TOMATO (2x1)

CUCUMBER (2x1)

BEAN (1)

CARROT (9)

PARSLEY (4)

ONION (5)

MARIGOLD (3)

CHARD (3)

BASIL (2)

LETTUCE (5)

RADISH (9)

NASTURTIUM (2)

tomato		cucumber	
carrot	bean	chard	basil
parsley	onion	radish	lettuce
marigold			nasturtium

All vegetable seeds are natural and free of rights. They were purchased from Kokopelli. Exception: the flower seeds (marigold and nasturtium). Below you find the english name and the french name of its variety.

Basil	Basilic "Grec"
Carrot	Carotte "COSMIC PURPLE"
Cucumber	Concombre "Long Vert d'Alan"
Chard	Côte de Blette "À Cardes Rouges Red Rhubarb"
Bean	Fève "D'Aquadulce"
Lettuce	Laitues à couper "Emerald Oak"
Onion	Oignon "Rouge de Huy"
Parsley	Persil "Persil simple (plat)"
Radish	Radis "Flamboyant"
Tomato	Tomates jaunes-oranges "Coeur de Boeuf Orange"



re-Make the world !

P2P Food Lab is not a product. It's a cause.

Current Food System

3'200'000 FARMERS/PRODUCERS



160'000'000 CONSUMERS

Food chain consolidation, by Jan-Willem Grievink. Used in 'Hungry City', by Carlyn Steel.

P2P Food Lab

in my neighbourhood

Jane grows vegetables.

Charles prepares soup.

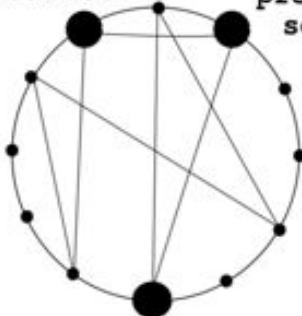

Marcus maintains the compost.

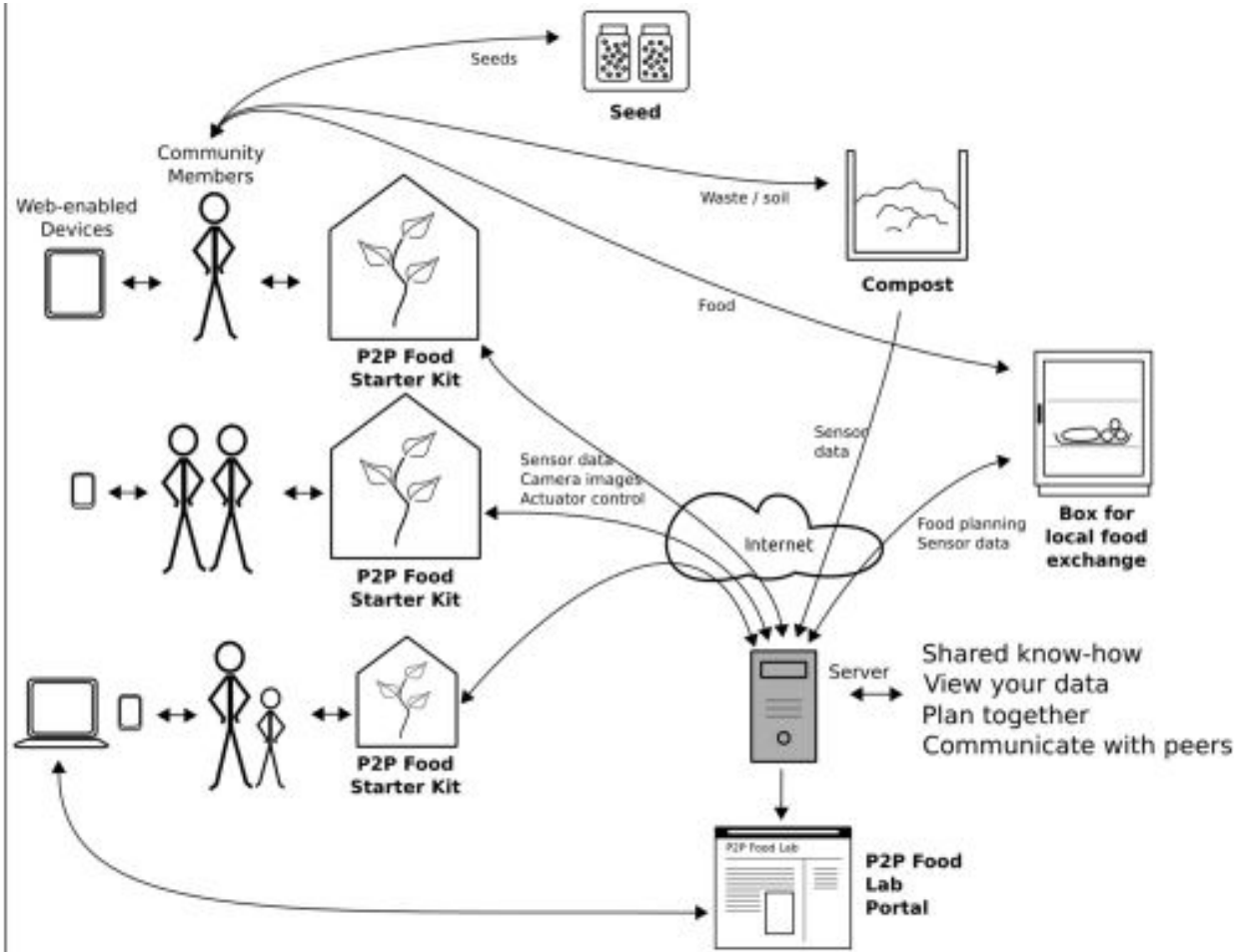

Bio ICT

The greenhouse as an energy and communication hub.

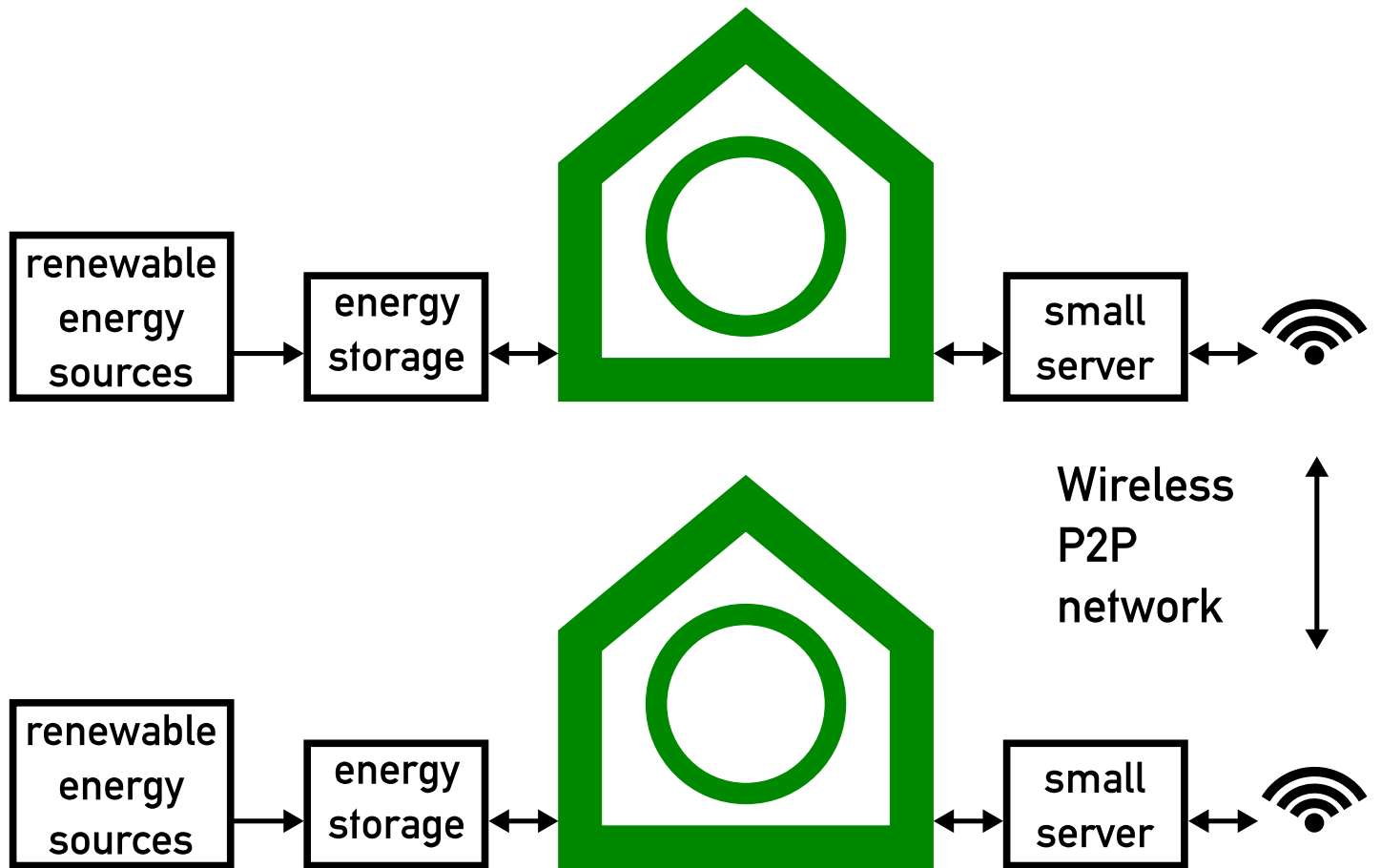

Join the P2P Food Lab project!

Build a greenhouse and tell us your experience.

Improve the design and share it with us.

Grow food and send us the pictures.

Provide tips and help for others on the web site.