

## Short communication. Platform for bee-hives monitoring based on sound analysis. A perpetual warehouse for swarm's daily activity

D. Atauri Mezquida<sup>1\*</sup> and J. Llorente Martínez<sup>2</sup>

<sup>1</sup> *Departamento de Sistemas Informáticos y Automática. Escuela Superior Politécnica.*

*Universidad Europea de Madrid. C/ Tajo, s/n. 28670 Villaviciosa de Odón (Madrid). Spain*

<sup>2</sup> *Entidad Estatal de Seguros Agrarios (ENESA). Ministerio de Medio Ambiente y Medio Rural y Marino (MARM). C/ Miguel Ángel, 23, 1.ª planta. 28010 Madrid. Spain*

---

### Abstract

Bees and beekeeping are suffering a global crisis. Constant information on swarm's conditions would be a key to study new diseases like colony collapse disorder and to develop new beekeeping tools to improve the hive management and make it more efficient. A platform for beehives monitoring is presented. It is based on the analysis of the colonies buzz which is registered by a bunch of sensors sending the data to a common database. Data obtained through sound processing shows plenty of patterns and tendency lines related to colonies activities and their conditions. It shows the potential of the sound as a swarm activity gauge. The goal of the platform is the possibility to store information about the swarm's activity. The objective is to build a global net of monitored hives covering apiaries with different climates, razes and managements.

**Additional key words:** *Apis mellifera*, environmental surveillance, honey bee, remote sensing.

### Resumen

#### Plataforma de monitorización de colmenas basada en el análisis del sonido. Un almacén permanente de la actividad diaria de los enjambres

Las abejas y la apicultura están sufriendo una crisis global. Disponer de información continua del estado de las colmenas puede ayudar al estudio de nuevas enfermedades, como el síndrome de desabejado, y al desarrollo de nuevas herramientas que mejoren la práctica apícola y la hagan más eficiente. Se presenta una plataforma de monitorización de colmenas basada en el análisis del sonido que producen los enjambres. Dicho sonido es recogido por una red de sensores y posteriormente analizado y almacenado en una base de datos. Los datos obtenidos a partir del sonido contienen gran cantidad de patrones y líneas de tendencia que pueden asociarse con comportamientos concretos de las colonias. Se muestra así el potencial del sonido como un indicador de la actividad y el estado de los enjambres. La fortaleza de la plataforma es la posibilidad de almacenar indefinidamente la actividad diaria de los enjambres. El objetivo es crear una red global de colmenas monitorizadas que cubra diferentes razas, climas y manejos.

**Palabras clave:** abeja, *Apis mellifera*, sensorización, vigilancia ambiental.

---

Honeybees are important pollinators of wild and commercial species, and an environmental sensor (Kevan, 1999). Beekeeping is also an important economic sector (MAPA, 2002).

To be aware of swarm conditions at every time is a key factor in those aspects. In commercial beekeeping

it reduces exploitation costs and ensures healthy and profitable hives. This has a strong impact on pollinating which becomes more effective (Ellis and Delaplane, 2008). Regarding environmental research, bees are excellent sensors for environmental changes as they react to pollution and contamination, species

---

\* Corresponding author: [david.atauri@uem.es](mailto:david.atauri@uem.es); [atauri@apilink.net](mailto:atauri@apilink.net)  
Received: 19-12-08; Accepted: 10-07-09.

Abbreviations used: CCD (colony collapse disorder), NASA (National Aeronautics and Space Administration), RMS (root mean square).

synchronization and introduction of genetically modified plants.

Bee research also requires more information from swarms than currently available. Colony collapse disorder (CCD) is an example of the need to save swarm's activity indicators. The problem is exposed by the United States Department of Agriculture (USDA, 2008): *Another issue complicating the research is that, so far, researchers only have samples taken after a CCD incident is reported. With just the one set of samples, especially since the adult bees have disappeared, researchers cannot look for specific changes in affected bee colonies preceding the collapse.*

Unfortunately, beekeepers cannot afford frequent inspections to the beehives, and bees dislike being frequently disturbed. This makes the information available usually very short. Moreover, information obtained during inspections is rarely integrated in an information system.

Problems in the colonies are often discovered too late to get a good solution and in many situations useful information is lost when needed.

The best way to store information about the activity of a swarm is to correlate its behavior with parameters registered by sensors. Some examples are bee counters (Liu *et al.*, 1990), swarm temperature and humidity, CO<sub>2</sub> level and weigh.

Sounds produced by swarms have been also studied. It is well known by beekeepers that swarm's buzz and its conditions are quite related, and it is possible to know if a hive is orphan or if great amount of nectar has been collected simply by listening to it.

Scientific research on sound has been focused on bees communication (Michelsen *et al.*, 1989; Dreller and Kirchner, 1995; Thom, 2003; Schneider and Lewis, 2004; Pastor and Seeley, 2005; Ferrari *et al.*, 2008).

Some tasks performed by bees, like fanning for example, produce sounds which have been considered a side product and have aroused little interest. However it seems that communication messages are not a significant part of the perceived buzz (Wenner, 1964; Kirchner, 1993; Boys, 1999).

A platform for bee-hives monitoring based on sound analysis is presented. The goal of the system is to check the hives in a systematic and continued way incorporating generated data into an information system. That creates a perpetual warehouse for data available for future research.

In addition to the information that could be obtained remotely from a hive and the possible tools that it

brings, another goal of the presented project is the possibility to build a global net containing information from different climates, bee razes and managements.

Specific hardware and software has been developed in order to continually monitor the sounds produced by bee-hives. The platform consists on a bunch of nodes and sensors: one node per apiary and one sensor per hive. Platform architecture is shown on Figure 1.

Nodes wake up the sensors as scheduled and sound samples are taken, processed and sent to a database. An application or a user can perform queries on the database to analyze data or create different reports.

Sensing devices were designed and built with the following features: i) omnidirectional microphone and 30 db amplification; ii) 8 bit digitize of each sound sample; iii) one temperature sensor; iv) wireless Zigbee communication (ZigBee-Alliance, 2006) with the node to avoid noise in wires and connectors; and v) digital signal processor.

Each sensing device is placed inside the hive, at the bottom of it, protected by a grid to avoid bees having access to the microphone.

Nodes are made up by an embedded PC computer (Epiak-8000 motherboard) with windows XP and solar powered (2\*50 watt panels). Applications were developed to save the sound and process it. Internet connection, needed to populate the database, can be provided via 3G modem or wifi when available.

The system has been installed on a 15 langstroth hives apiary in Sierra de Guadarrama (Madrid, Spain). Up to 10 hives are being monitored continually taking sound samples each hour.

Each sound sample is 8 seconds long. Sampling rate is 6,250 Hz so the higher frequency the system can record is 3,125 Hz according to Nyquist theorem. This is much higher than maximum frequency cited on scientific literature which locates it on 700 Hz (Ishay and Sadeh, 1982; Dietlein, 1985). Recent research has registered 6 kHz hissing under wasps attack (Papachristoforou *et al.*, 2008). This behavior is very rare and not covered by the system.

Each sample has the following information:

- Locality.

- Hive name.

- Julian day and percent of it: *i.e.* 165.0 and 166.99 means sunset, 165.25 means midnight, 165.5 means sunrise and 165.75 means noon. This nomenclature enables comparison between samples on different seasons: sunset or noon relates to swarm activity better than punctual hours.

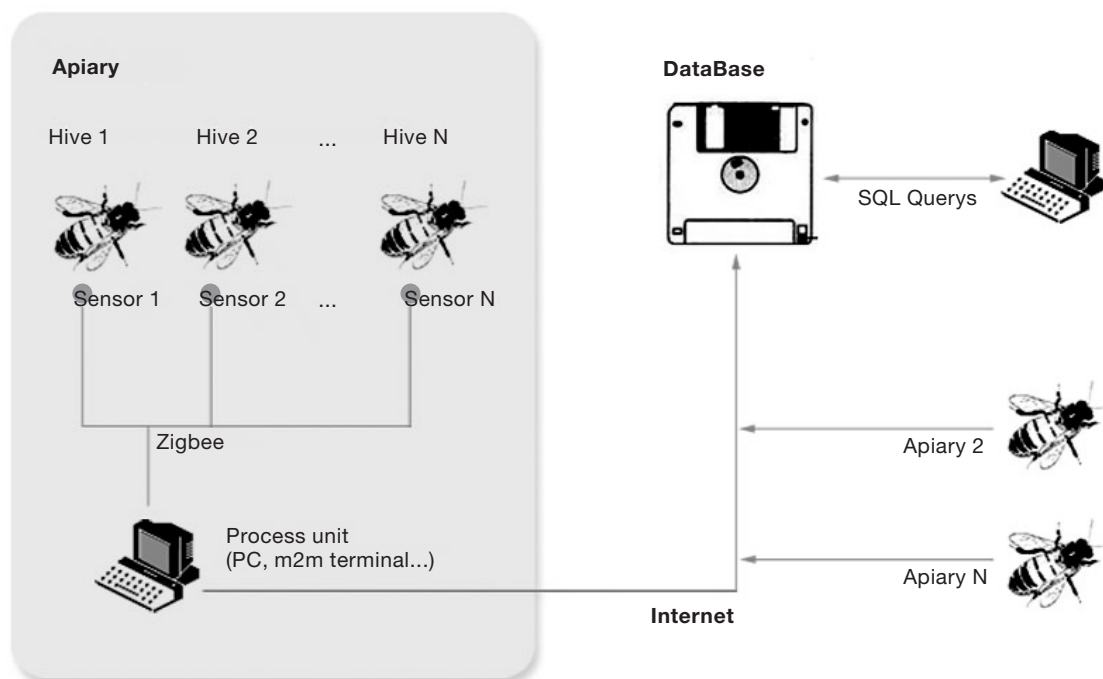

Figure 1. Platform architecture.

- Temperature outside the hive.
- Temperature inside the hive.
- RMS (root mean square): power of the audio waveform measured in watts, calculated by the following formula:

$$\text{RMS} = [\sum(x_i)^2]^{1/2} / n,$$

where  $x_i$  represents amplitude of each sound sample and  $n$  the total amount of samples.

- Rugosity: a suggested index that takes into account how much the wave varies. A continuous signal has low rugosity index while a «crunchy» and noisy wave has higher rugosity. It is calculated with the following formula:

$$\text{Rugosity} = [\sum(x_i - x_{i-1})^2]^{1/2} / n.$$

- Main frequencies: Fourier transform is calculated over sound samples to get its frequency spectrum. The five main frequency bands (tone and intensity) are located on the spectrum and stored. Data obtained from frequency spectrum is explained on Figure 2. This process is unattended so it is susceptible of being automated and applied to huge amounts of data.

All the data obtained from different sound samples are stored in a database so they can be easily filtered, sorted and grouped by different criteria using SQL language.

Series resulting from queries are very often temporal series showing how parameters vary over time. Those series can be painted and analyzed using statistical techniques, data mining, temporal series analysis, or automatic summarization.

The system is installed and currently running on <http://apilink.net> where a web application can be used to graph stored data. Records started on 20<sup>th</sup> May, 2008 and 26,774 samples were stored by 4<sup>th</sup> April, 2009.

Database was implemented in MySQL5.0. All applications running on nodes for signal processing

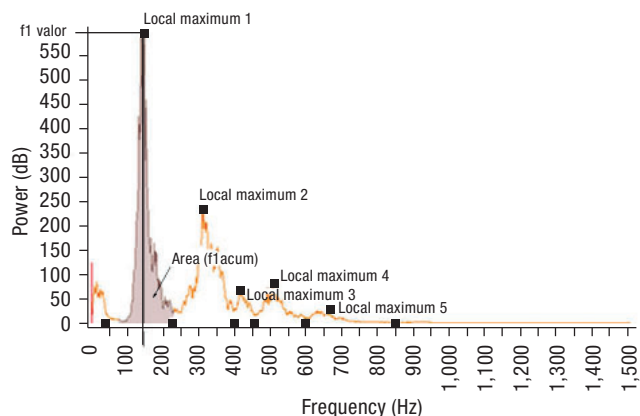

Figure 2. Frequency spectrum of a sound sample and parameters obtained from it.

were developed on Borland C++ Builder release 6. Sensing device software was developed on ANSI C. Web application for database viewing was developed on Adobe Flex3 and PHP5.

Information stored on the database allowed searching for patterns, tendency lines and changes on them. Database can be accessed via SQL language. SQL flexibility makes the ways to filter, group, sort and combine data practically unlimited.

Some parameters like volume of the sound, and sound intensity at medium and low frequency bands showed daily patterns, primarily on spring. Volume of the sound did not show such clear patterns in winter. Figure 3a shows how the volume of the sound varied in three different hives in early spring. Green line corresponds to a hive with eight brooded combs, red line corresponds to five brooded combs hive; blue line to a three brooded combs hive infected by *Ascosphaera apis*. It seems to be a highly significant relation between sound volume and swarm's size, but more experiments are needed to measure it.

Not all the parameters showed daily patterns. Sound intensity was commonly low at high frequency bands (upper than 300 Hz) but very high under stress, like after joining two swarms.

Some other parameters, like the main tone of the different frequency bands, were mostly constant (Fig. 3b) but under certain circumstances showed abrupt changes. In certain hives and periods of time, those parameters showed gradual changes over several days. Guided experiments would try to figure out its meaning.

As long as different indicators have different evolutions, relations existing between couples or groups of parameters could also reveal patterns or tendency lines.

SQL queries can also group database registries, obtaining from each group its average, maximum, or minimum value. These sentences can provide comparisons between several apiaries (averaging all their hives) or between periods of time. Registries can also be grouped by any field in the database increasing possibilities of data interpretation.

The amount of parameters that can be obtained from the sound, and the huge amount and diversity of patterns found in those parameters reveals the potential of the sound to examine swarm's conditions and behaviors. To figure out all the information the buzz might content is a huge mission that should be faced up in a collaborative way.

Predicting tools based on sound like Apidictor (Woods, 1959) and Bee Tone Analyzer (Vancata, 1995) were used during an inspection at the apiary at any time. These tools meant great advances in those days, but their tools did not take samples systematically and could not check behaviors that should hide daily patterns. Information obtained was not integrated in an information system.

Other systems like bee counters or scales can take samples systematically. NASA (National Aeronautics and Space Administration) is building a net and saving the hive's weigh over time (NASA, 2008) in order to study global warming. However, sound is a richer

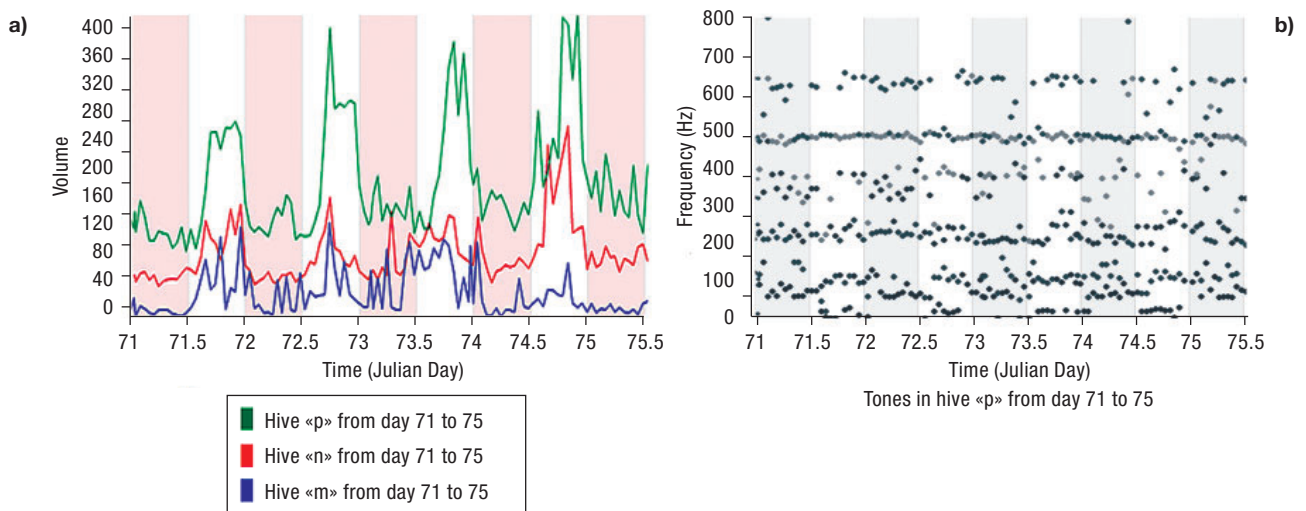

**Figure 3.** Variations of the volume of the sound of three different hives from 2<sup>nd</sup> to 17<sup>th</sup> March, 2009 (a) versus variations of the tone on main frequency bands in one hive (b).

indicator involving more parameters, some of which react faster to changes in swarm's state enabling alarm systems development.

Anyway those parameters are compatible with sound and could enrich the warehouse if added to the presented system.

Scale based systems, like NASA's mentioned above, require expensive frames or skeletons as well as a leveled floor and calibration to enable comparison between different hives. By this reason the growing potential of the net is reduced. Moreover, some hives are not suitable for scales such as feral or migrating hives.

Constant information on colonies conditions, based on hive's buzz, would improve beekeeping techniques reducing costs and enabling the development of alarm systems. It could also be of help in environmental surveillance. New diseases like colony collapse disorder and other problems like global warming could have a better approach if daily activity of many colonies over several years would have been stored.

The next step in the development of this platform should be the growth of the net adding new nodes and the realization of new experiments to better understand the swarm's buzz.

## Acknowledgements

My gratitude to José Serrano and Francisco Padilla for their comprehension on the technical failures and delays. This study was supported by project API06-010-COORD-2 from the Spanish Ministry of Agriculture, Fishery and Food and FEOGA.

## References

- BOYS T.R., 1999. Listen to the bees. [on line]. Available in <http://beedata.com/data2/listen/listenbees.htm> [20 Jun, 2009].
- DIETLEIN D.G., 1985. A method for remote monitoring of activity of honeybee colonies by sound analysis. *J Apicult Res* 24(3), 176-183.
- DRELLER C., KIRCHNER W.H., 1995. The sense of hearing in honey bees. *Bee World* 76(1), 6-17.
- ELLIS A., DELAPLANE K.S., 2008. Effects of nest invaders on honey bee (*Apis mellifera*) pollination efficacy. *Agr Ecosyst Environ* 127(3-4), 201-206.
- FERRARI S., SILVA M., GUARINO M., BERCKMANS D., 2008. Monitoring of swarming sounds in bee hives for early detection of the swarming period. *Comput Electron Agr* 64(1), 72-77.
- ISHAY J.S., SADEH D., 1982. The sounds of honey bees and social wasps are always composed of uniform frequency. *J Acoust Soc Am* 72(3), 671-675.
- KEVAN P.G., 1999. Pollinators as bioindicators of the state of the environment: species, activity and diversity. *Agr Ecosyst Environ* 74(1-3), 373-393.
- KIRCHNER W.H., 1993. Acoustical communication in honeybees. *Apidologie* 24, 297-307.
- LIU C., LEONARD J., FEDDES J.J., 1990. Automated monitoring of flight activity at a beehive entrance using infrared light sensors. *J Apicult Res* 29(1), 20-27.
- MAPA, 2002. Libro blanco de la agricultura y el cambio rural. Ministerio de Agricultura, Pesca y Alimentación, Madrid, Spain. [In Spanish].
- MICHELSSEN A., ANDERSEN B.B., KIRCHNER W.H., LINDAUER M., 1989. Honeybees can be recruited by a mechanical model of a dancing bee. *Naturwissenschaften* 76, 277-280.
- NASA, 2008. HoneyBeeNet. [on line]. Available in <http://honeybeenet.gsfc.nasa.gov/About.htm> [20 Jun, 2009].
- PAPACHRISTOFOROU J.S., SUEUR J., RORTAIS A., ANGELOPOULOS S., THRASYVOULOU G.A., 2008. High frequency sounds produced by Cyprian honeybees *Apis mellifera* cypria when confronting their predator, the oriental hornet *Vespa orientalis*. *Apidologie* 39, 468-474.
- PASTOR K.A., SEELEY T.D., 2005. The brief piping signal of the honey bee: begging call or stop signal? *Ethology* 111(8), 775-784.
- SCHNEIDER S., LEWIS L., 2004. The vibration signal, modulatory communication and the organization of labor in honey bees, *Apis mellifera*. *Apidologie* 35, 117-131.
- THOM C., 2003. The tremble dance of honey bees can be caused hive-external foraging experience. *J Exp Biol* 206, 2111-2116.
- USDA, 2008. Colony collapse disorder. A complex buzz. *Agricultural Research Magazine* 56(5), 10-13.
- VANCATA O., 1995. Using acoustic technology to monitor your hives. *Am Bee J* 135(9), 615-618.
- WENNER A., 1964. Sound communication in honeybees. [on line]. Available in <http://www.beesource.com/pov/wenner/>. [20 Jun, 2009]
- WOODS E.F., 1959. Electronic prediction of swarming in bees. *Nature* 184, 842-844
- ZIGBEE-ALLIANCE, 2006. Zigbee specification [on line]. Available in <http://www.zigbee.org> [19 Sept, 2008].